

DS-700 Vertical Axis Wind Turbine

User Manual

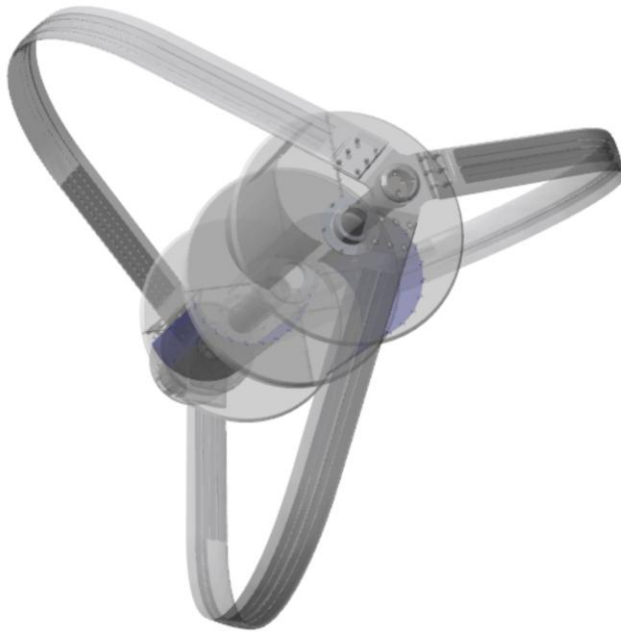

Hi-VAWT Technology Corporation
www.hi-vawt.com.tw



Version 2.

Table of Contents

WARNING	5
DISCLAIMER	6
1. Safety Precautions	8
1.1 Mechanical Hazards	9
1.2 Electrical Hazards	9
1.3 Assembly	10
1.4 Installation	11
1.5 Operation	12
2. Introduction	13
2.1. DS-700 Specification	14
2.2. DS-700 Standard Packing	15
2.3. DS-700 Wind Power System Controllers	17
2.4. DS-700 Optional Parts	18
3. Preparation of Assembly and Installation	19
3.1 Selecting Location	19
3.2 Mast Preparation	20
3.3 Foundation Guide for DS-700	25
3.3.1 Ground Foundation	26
3.3.2 Roof Foundation	29
4. DS-700 Assembly and Installation	32
4.1 Tools Required for Assembly and Installation	32
4.2 DS-700 VAWT Assembly	33
4.3 DS-700 Installation	37
5. Wiring	43
5.1 General Information	43

5.2 DS-700 Wire Size 43

5.3 DS-700 Wiring Diagram..... 44

5.4 Grounding..... 47

5.5 Fusing..... 47

6. Warranty..... 48

Table of Figures

Figure 2-1 General View of the DS-700 VAWT System 13

Figure 2-2 DS-700 Standard Packing Contents 17

Figure 2-3 System Controllers 18

Figure 3-1 Dimension for Mast 22

Figure 3-2 Optional Mast Design 24

Figure 3-3 Ground Foundation Construction Reference 26

Figure 3-4 Anchoring Templates 28

Figure 3-5 Foundation for Roof Installation Reference 30

Figure 4-1 Required Tools for Assembly and Installation..... 32

Figure 4-2 DS-700 Assembly Procedures - 1 34

Figure 4-3 DS-700 Assembly Procedures - 2 35

Figure 4-4 DS-700 Assembly Procedures - 3 37

Figure 4-5 DS-700 Installation Procedures - 1 38

Figure 4-6 DS-700 Installation Procedures - 239
Figure 4-7 DS-700 Installation Procedures - 340
Figure 4-8 DS-700 Installation Procedures - 442
Figure 5-1 Wiring Diagram for Wind Energy MPPT Charger (MAX-1000)
.....45

Table Index

Table 2-1 DS-700 Technical Specification 14
Table 2-2 DS-700 Components 15
Table 5-1 Wire Sizing Reference.....44
Table 5-2 DS-700 Wiring Size Reference (MAX-1000).....46

WARNING

THIS USER' MANUAL PROVIDES INSTRUCTIONS AND GUIDELINES FOR ASSISTANCE WITH ASSEMBLY AND INSTALLATION OF THE HI-VAWT'S DS-700 VERTICAL AXIS WIND TURBINE. ALTHOUGH THE DS-700 VAWT HAS BEEN DESIGNED AS EASY AS POSSIBLE FOR THE INSTALLATION, IT STILL REQUIRES SPECIALIZED SKILLS, TOOLS AND EXPERIENCE AS WELL. FOR THE PURPOSES OF ASSEMBLING, INSTALLING, OPERATING AND MAINTAINING THE DS-700 VAWT, WE ASSUME THAT PERSONNEL WHO INVOLVED IN THE WHOLE PROCESSES HAS THE SKILLS, TOOLS REQUIRED TO DO SO. NO ONE SHOULD ATTEMPT TO ASSEMBLE, INSTALL, OPERATE AND MAINTAIN THE DS-700 VAWT SYSTEM WITHOUT THE NECESSARY SKILLS, EXPERIENCE, TOOLS AND SAFETY EQUIPMENT.

DISASSEMBLING THE PARTS FROM ORIGINAL IS RESTRICTED. ALL PRE-ASSEMBLED PARTS ARE FACTORY ADJUSTED, BALANCED AND TESTED. HI VAWT TECHNOLOGY CORPORATION ASSUMES NO WARRANTIES AND LIABILITIES OF DOING SO.

HI-VAWT TECHNOLOGY CORPORATION (Hi-VAWT) ASSUMES NO DIRECT OR CONSEQUENTIAL LIABILITY IF FAULTY OR DANGEROUS ASSEMBLING, INSTALLATION OR MAINTENANCE PRACTICES ARE PERFORMED. PLEASE CONTACT HI-VAWT TECHNOLOGY CORPOATION IF CONSULTATION OR ASSISTANCE IS REQUIRED.

HI-VAWT RECOMMENDS THE DS-700 VAWT SYSTEM SHOULD BE SITED ACCORDINGLY IN AN EXCLUSION ZONE WITH CONTROLLING PUBLIC ACCESS. APPROPRIATE WARNING SIGNS SHOULD BE PLACED ON THE OPERATING SITE.

THE DS-700 SHOULD NOT BE INSTALLED NEAR UNPROTECTED POWER LINES, TREES OR ANY OBJECTS THAT WOULD POSSIBLY CAUSE THE HAZARDS OF THE OPERATION.

Hi-VAWT Technology Corporation

No. 168, Jhu-lin 1st Rd., Lin-kou District, 244, New Taipei City, Taiwan

Tel: +886-2-8601-4373

Fax: +886-2-8601-1263

E-Mail: sales@hi-vawt.com.tw

Website: www.hi-vawt.com.tw

DISCLAIMER

Although Hi-VAWT recommends reading the entire manual thoroughly prior to assembly and installation to ensure proper performance and safety, this manual is intended as a guide only. It should not be considered as a replacement of professional services or as a

definitive text for assembling and installing the DS-700 VAWT systems.

Hi-VAWT makes no warranties by either expressed or implied that the information contained in the manual is accurate or complete. Hi-VAWT Technology Corporation makes no warranties of fitness for a particular purpose and /or site. Hi-VAWT will not be responsible for any direct or consequential damages, or an incidental expense.

All instructions, figures and diagrams are believed to be accurate at the time of printing. The success and safety in working with tools depend greatly on individual accuracy, skill and caution. For this reason, Hi-VAWT is not able to guarantee the result of any contained procedure in the manual, nor can they assume responsibility for any damage to property or injury to persons resulting from procedures contained in this manual. Persons who engage in the procedures take their own responsibility and risk.

Actual power resources and selected site conditions will highly affect the energy production, which will vary with wind turbine maintenance, surrounding environment, therefore, Hi-VAWT makes no representation or warranties regarding energy production.

Wind generators, like other sources of electrical power, Must be installed following the guidelines established by local and national regulations. Please consult a local electrical contractor for details and regulations.

The information and all specifications contained within this manual are subject to change without notice.

1. Safety Precautions

The DS-700 is designed with user safety in mind. However, there are inherent dangers involved with any structural, mechanical and electrical equipment, the surrounding environment as well.

Safety must be the primary concern as you plan the location, assembly, installation and operation of the DS-700 VAWT. At all times be aware of electrical, mechanical and rotor blade hazards.

This Owner's Manual contains important instructions, guidelines and safety notes that should be followed during the installation and maintenance of the Hi-VAWT's DS-700 VAWT.

Please read thoroughly and follow the instructions in this USER'S MANUAL before assembling and installing the DS-700 VAWT.

Please refer to the following symbols which are used throughout this manual to indicate potentially dangerous situations, important safety instructions or important notes for you to know.



This WARNING symbol indicates a possible dangerous condition.

Please use extreme caution when

processing the procedure.



This CAUTION symbol identifies an improper operation that could result in critical safety issue or damage to the system controller or related devices.



The NOTE symbol describes an important procedure or issue for you to know to properly and safely operating the device.

1.1 Mechanical Hazards

Rotating blades present the most serious mechanical hazard. The DS-700's rotor blades are made of very strong anodized aluminum. Some edge of the blades are sharp, please do not touch those sharp blades. Even though, with the built-in airfoil, the edges of those blades are not as sharp, they still will cause serious injury when they start rotating, even at low speed.



- NEVER TOUCH THE RUNNING ROTOR.
- NEVER TRY TO STOP THE RUNNING ROTOR BY HAND.
- DO NOT INSTALL THE DS-700 VAWT SYSTEM WHERE ANYONE CAN APPROACH THE PATH OF THE BLADES.
- AVOID ANY OBJECTS TOUCHING THE RUNNING ROTOR.

1.2 Electrical Hazards

The DS-700 VAWT System is equipped with sophisticated generator and designed to provide protection from electrical dangers.

Heat in wiring systems is often a result of too much current flowing through and undersized wire or through a bad connection. It is important to follow the suggested wire-sizing chart to ensure a safe electrical system

The battery, if applied, should never be short-circuited as it will result a danger of setting the battery and cable on fire. In order to avoid the threat and protect the cabling, fuses should be installed in the lines connecting to the battery.



WARNING

- WIRING CABLE WITH INSUFFICIENTLY DIMENTION CROSS SECTION CAN CAUSE ELECTRICAL FIRE.
- NEVER SHORT-CIRCUIT THE BATTERY IF APPLIED.

1.3 Assembly

The DS-700 VAWT System is designed in “All Most Ready to Use” format and shipped with factory pre-assembled packing. The only assembly work required is Darrieus blades assembly. This user’s manual will guide you through the assembly procedures with detailed illustrations.



NOTE

- Please carefully read the assembly instructions in this manual before proceeding.
- It is important to have a suitable working environment for performing the assembly tasks.

- Refer to the suggested list of tools required for the assembly and have all of them ready before proceeding.



WARNING

- PLEASE ALWAYS KEEP SAFETY IN MIND WHILE PERFORMING THE ASSEMBLY PROCEDURES.
- ALWAYS WEAR SAFE HELMET AND GLOVES!

1.4 Installation

A fall from the height at which a wind turbine is ordinarily mounted will often result in death or serious injury. Therefore whenever practicably carry out as much work as possible on the wind turbine at ground level. If it is necessary to work on the installation at such height then use an appropriate access system such as a mast that is designed to carry the load of a person; a man-rated winch or rope access system; a hydraulic lift or other safe working platform. Wear appropriate safety equipment and make the general working area as tidy and safe as possible. Work during the daylight on windless days. Above all else think carefully about what you need to do and plan your work carefully, have all the tools and equipment ready before your start.



CAUTION

- Installation procedures should be performed as much as possible at ground level.
- Use safety harnesses, safe helmets, gloves, etc.
- Make sure that all batteries, if applied, are disconnected from the system throughout the installation process.

- The DS-700 generator should be short-circuited to prevent unintended wind turbine rotating during the shipment. Please install the extension cable on the ground level and keep it short-circuited throughout the installation process.
- Please keep the rotor straight up or lie on the support stands at all-time during the installation process to prevent the blades twisted or lost balance.
- Please perform the installation at a calm and windless day.

1.5 Operation

Please check the support structures, blades and electrical system on regular basis.

- Even though the rotor blades are very strong, however, if they come in contact with a solid object, they can be damaged or even broken.
- When perform routine inspections, or at anytime you must approach the path of the blades, please disconnect the power leads from the batteries and short-circuit the wind turbine output leads (use the Stop Switch after installation or tie the output leads together) to stop the rotor blades from rotating. The DS-700 is designed to be shut down through the use of stop switch (brake switch).
- NEVER APPROACH THE TURBINE DURING OPERATION.

2. Introduction

The DS-700 is a hybrid Vertical Axis Wind Turbine (VAWT) system which combines drag-based design and lift-based design. It incorporates an S-type of Savonius rotor and three airfoil blades of egg-beater shape Darrieus to maximize the output performance.

The following Figure 2-1 shows a general view and major components of the DS-700 VAWT System.

Figure 2-1 General View of the DS-700 VAWT System

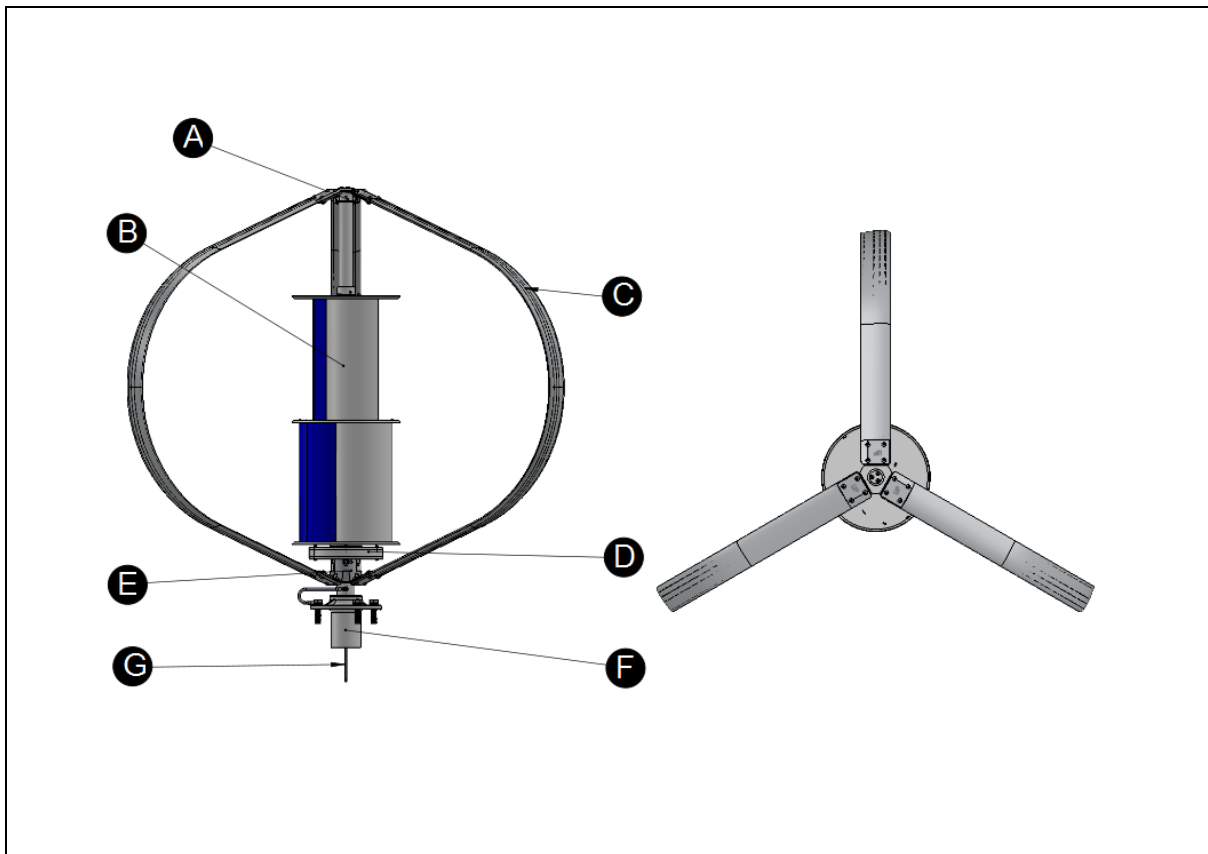

Parts	Description
A	Upper Darrieus Blades Connector.
B	S-Type Savonius.

C	3 Darrieus blades with built-in airfoil.
D	3-Phase, Direct Drive, Weather Sealed, Mechanically Integrated Permanent Magnet Generator.
E	Lower Darrieus Blades Connector.
F	Damper.
G	3-Phase R-S-T Generator Wires.

2.1. DS-700 Specification

The following table shows the technical specification of the DS-700 Wind Turbine.

Table 2-1 DS-700 Technical Specification

General Dimension	
Rotor Diameter:	1,930 mm
Height:	1,547 mm
Weight:	52 Kgs
Blades	
Number of Blade:	3
Blade Material:	Anodized Aluminum
Operation Mode	
Cut-In Wind Speed:	<3 m/s
Cut-Out Wind Speed:	15 m/s
Survival Wind Speed:	60 m/s (3-seconds gust)
Safety Mechanism	
Over Speed Braking:	Yes. (Setup by Power Controller)
Manual Brake:	3-phase short-circuit Switch
Generator	
Type:	AC, Direct Drive, Weather Sealed, 3-Phase Synchronism PMG.

Rated Output:	700 W @ 12 m/s
Mounting	
Foundation Mounting:	Min. Height above ground: 3 meters.
Roof Mounting:	Min. Height above roof: 2 meters.
Bedplate Mounting:	Used where deep excavation cannot be applied
Warranty	
Limited Warranty:	1 year on components.

2.2. DS-700 Standard Packing

Please check all components you receive from the shipment with the packing list that comes with the purchase invoice or the enclosed parts list in the shipment. Ensure that you receive all standard components or parts for the DS-700 accordingly. If any missing parts from the original packing, please contact Hi-VAWT Technology Corporation for replacement.

Table 2-2 shows the standard packing of DS-700 VAWT System. Please also refer to Figure 2-2 for part locations. Detail assembly instructions will be discussed in the *Chapter 4 - Assembly and Installation*.

Table 2-2 DS-700 Components

Labels	Description	Quantity Included
--------	-------------	-------------------

A	Anodized Aluminum Blade (Assembly Needed)	3
B	Pre-assembled Components	1 Set
1	Upper Blades Connecting Plate	1
2	S-Type Savonius	1
3	Vertical Axis	1
4	700W PM Generator	1
5	Lower Blades Connecting Plate	1
6	R.S.T. Generator Wiring Cables	3
7	Mast Connector with Damper	1
8	Wind Turbine Surge Wire (Connected between Damper and Flange of the Mast)	1
C	Bolt Sets	
1	M10 x 30mm Button Hex Head Bolts and Nuts (Set)	18
2	M8 x 30mm Button Hex Head Bolts and Nuts	6
3	M20 x 60mm Hex Head Bolts/Washers	8
7-1	Set Screw M10 x 10mm	2
7-2	Socket Countersunk Head Cap Screw M8 x 16mm	2
8-1	M10 x 20mm Hexagon Socket Head Bolt and Nut (Set)	1

Figure 2-2 DS-700 Standard Packing Contents

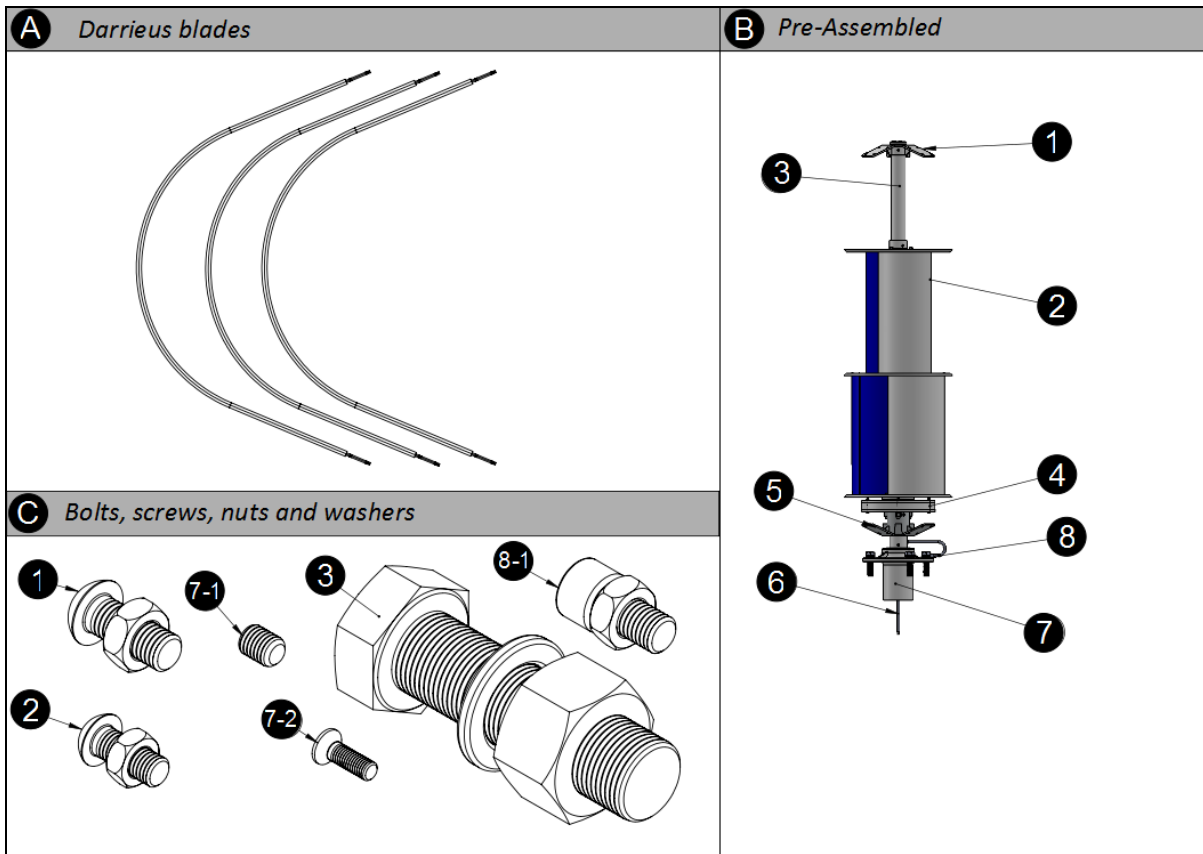

2.3. DS-700 Wind Power System Controllers

The standard wind energy MPPT charger is MAX-1000 for DS-700 VAWT off grid application. The descriptions and specifications of MAX-1000 Controllers are detailed in user's manual respectively.

Figure 2-3 shows the standard DS-700 Wind Power System Controllers.

Figure 2-3 System Controllers



2.4. DS-700 Optional Parts

This DS-700 VAWT System is designed with simplicity in mind, so there are just a few parts needed which all included in the standard package. Concerning the shipping cost and different applications applied by customers, the required mounting mast to setup the DS-700 Wind Turbine is not included in the standard package. It would be an optional part based on customer's choice.

The detail description of the mounting mast will be explored in Chapter 3.

3. Preparation of Assembly and Installation

Before going through the DS-700 VAWT System installation procedures, please double check parts included in the package. Prepare all required tools and equipments accordingly and have them ready on hands. More importantly, all safety issues have been well thought and followed.

3.1 Selecting Location

The DS-700 Wind Turbine is designed with flexibility to fulfill user's applications. It can be installed along the street, sea shore, on the mountain, in the city, urban area, or just right on top of the roof of the building. The major key factor of affecting the performance of DS-700 Wind Turbine for all proposed applications is the location of optimizing wind energy.

NOTE

We assume that the proposed site of installing the DS-700 VAWT System has been well evaluated by users themselves for optimizing the wind energy environment before any installing procedures performed.

WARNING

- DO NOT install the DS-700 VAWT System at a site where anyone can easily approach the rotating blades.
- DO NOT install the DS-700 VAWT System at a site surrounded by obstructions. For example, Trees, power lines, etc.
- DO NOT install the DS-700 VAWT System at a site with improper structure to hold the DS-700 System.

 **CAUTION**

- Always follow your local regulations, codes about restrictions applied to such system installation.
- Always have your DS-700 grounded to avoid the lightning strike.
- Perform the installation of the DS-700 VAWT System in a calm and windless day.
- Perform all required assembly for the DS-700 VAWT System at ground level.

3.2 Mast Preparation

As mentioned before, shipping charge of the mast made by Hi-VAWT will be costly. If you prefer making your own mast for DS-700 VAWT System rather than purchasing from Hi-VAWT, we will show you here how the mast can be made by your local supplier.

In the Figure 3-1, the Mast Specification was originally designed and tested on the DS-700 VAWT System. It has been approved and applied as the standard DS-700 VAWT System. It is important to follow the diameters shown in Figure 3-1 for Mounting Flange and Mast of the DS-700 VAWT System.

 **CAUTION**

- Please carefully check the structure of the building if you are going to install DS-700 VAWT System on the roof. Make sure

the structure is strong enough to endure DS-700 VAWT System in terms of total weight, impact from gusty wind or earthquake, etc. Hi-VAWT Technology Corporation suggests the length of the mast is 2 meters for the roof installation and 6 meters for the ground.

- Carefully check the surrounding area when determines the length of the mast. Avoid any existing objects that affect the performance of wind energy or cause hazards.

The following Figure 3-1 shows the diagram for making the mast.

Figure 3-1 Dimension for Mast

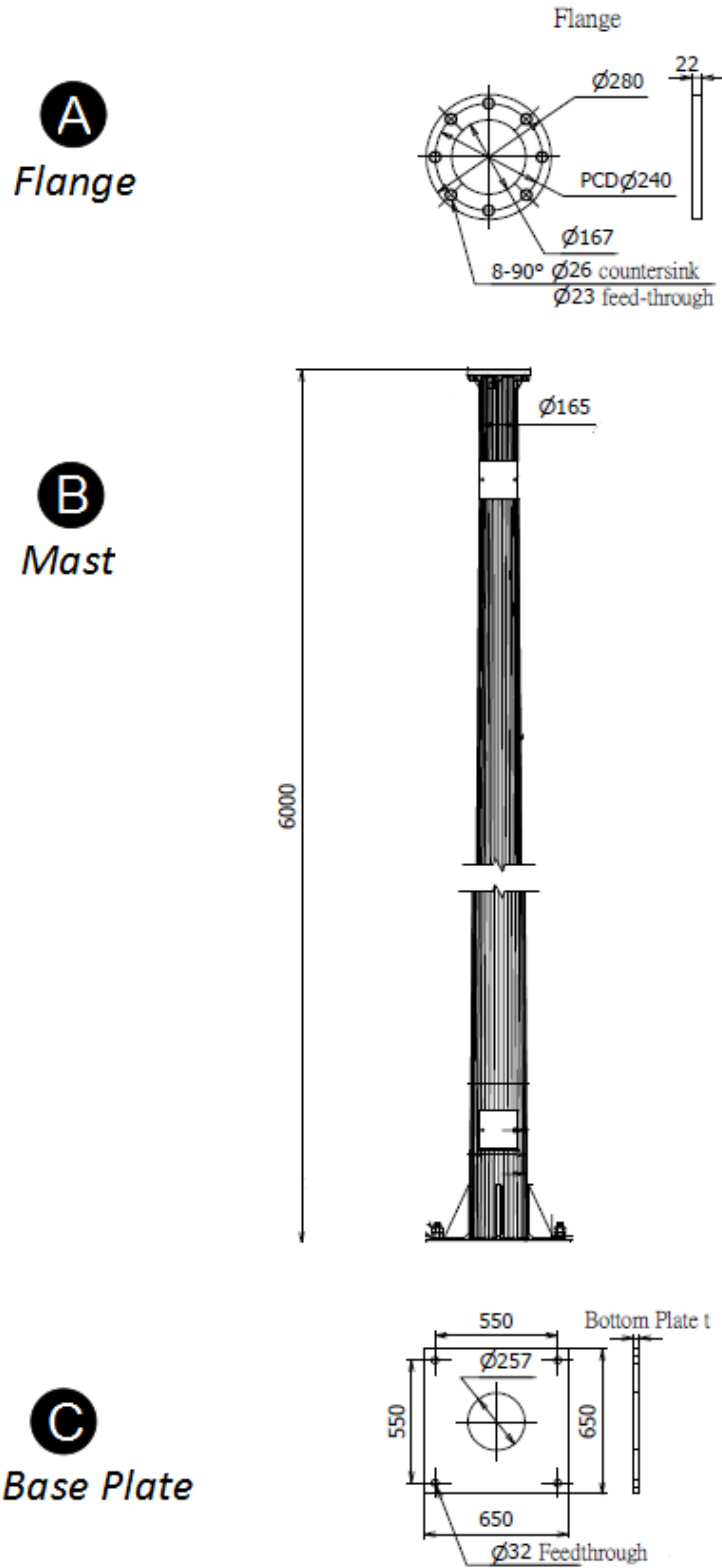

<p style="text-align: center;">A</p>	<p>This portion shows the dimension of the mounting flange which should be welded on top of the mast for connection with the DS-700 VAWT System.</p> <ul style="list-style-type: none"> • Flange Inner Dia. = $\varnothing 165.2\text{mm}$ • Flange Outer Dia. = $\varnothing 280\text{mm}$ • 8 - $\varnothing 22\text{mm} \times P1.25$ Tapped bolt holes on PCD $\varnothing 240\text{ mm}$ (45° each) • Flange thickness = 18mm
<p style="text-align: center;">B</p>	<p>Mast Dimension:</p> <ul style="list-style-type: none"> • Mast Outer Dia.(top) = $\varnothing 165\text{mm}$ • Mast Outer Dia.(bottom) = $\varnothing 258\text{mm}$ • Thickness = 5 mm • Standard Length of the Mast = 6000mm • Mounting flange welded on the top of the Mast. • Foundation Plate welded under the bottom of the Mast with 4 support ribs (t=12mm). • Drill a 18.5mm diameter hole at 30mm above the bottom of the mast. This hole is reserved for wiring cable exit. If an underground conduit is applied in the concrete foundation, then ignore this exit.
<p style="text-align: center;">C</p>	<p>Foundation Plate Dimension:</p> <ul style="list-style-type: none"> • 650mm x 650mm • Thickness = 18mm • 4 x $\varnothing 28\text{mm}$ bolt holes with 550mm x 550mm spacing. • 4 x 12mm in thickness of support ribs

Figure 3-2 shows an optional design of the mounting mast. You may use hinge type mechanism at one side of the foundation plate to make an easy way to access the DS-700 by lowering down or lifting up the mast.

Figure 3-2 Optional Mast Design

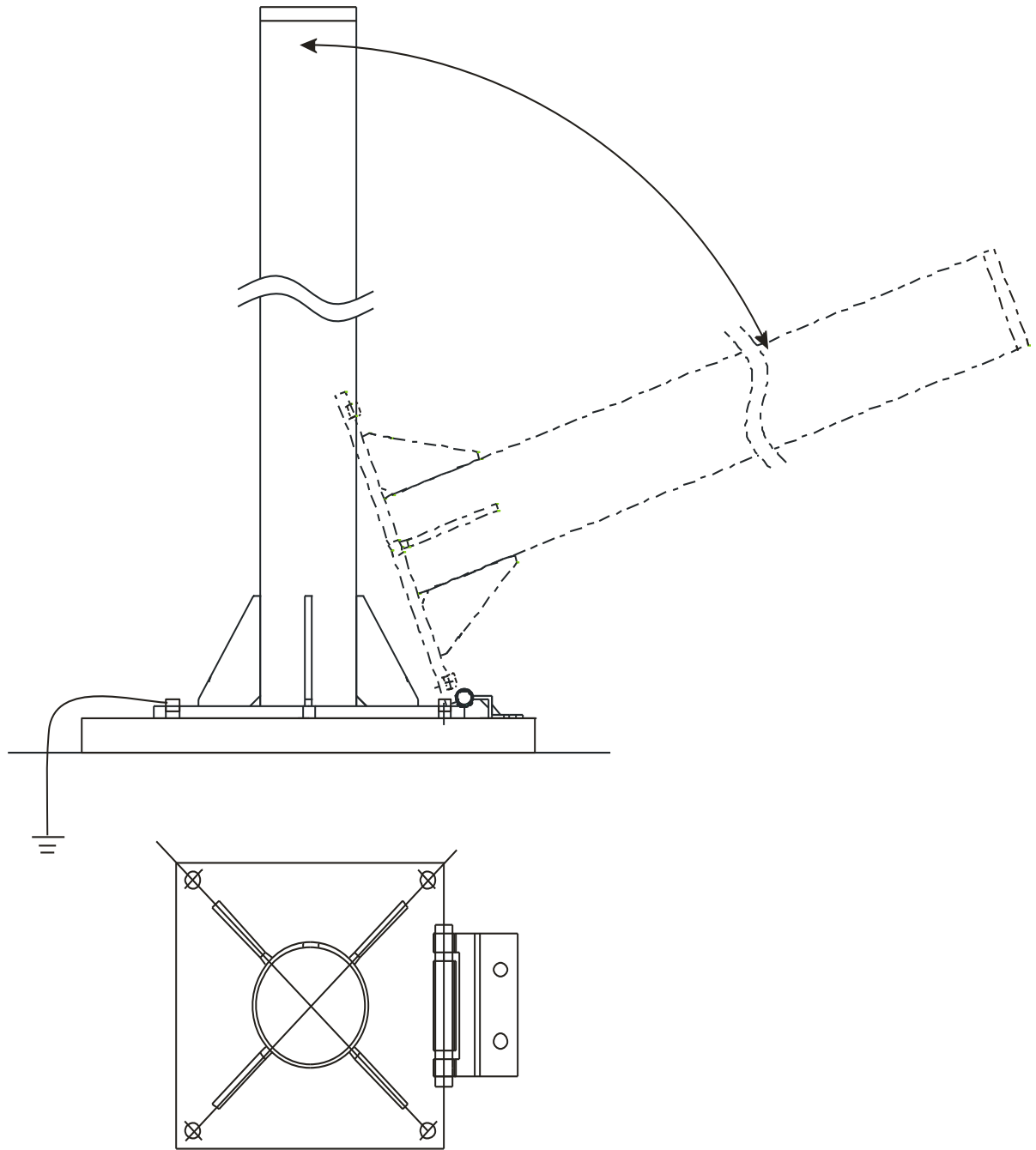

3.3 Foundation Guide for DS-700

Before constructing the foundation for the DS-700 VAWT System, read these instructions carefully. These instructions are only intended to be a guide for concrete foundations on solid soils or suitable roof infrastructure. Please contact your local civil or structure engineer for more information.

3.3.1 Ground Foundation

Based on Hi-VAWT's standard 6m mast design to accommodate 52.5 m/s extreme wind condition (Wind Class III) on top Sand, silty sand, clayey sand, silty gravel and clayey gravel (IBC Soil Class 4), the foundation should be prepared as 1.362 cubic meter in dimension (850mm x 850mm x 1200mm) depth, dug into the soil. Please follow the diagram shown in the Figure 3-3.

Make a template of the mast bottom. This template will be temporarily used for holding four Anchor Bolts vertically and electrical conduit (if applied) in the precise position while pouring concrete into the foundation hole later.

- Follow the Figure 3-4 diagram and make anchoring templates with steel plate. These templates will be used to hold four anchors bolts vertically and electrical conduit (if applied) on the precise position while pouring concrete into the foundation hole later.

Figure 3-3 Ground Foundation Construction Reference

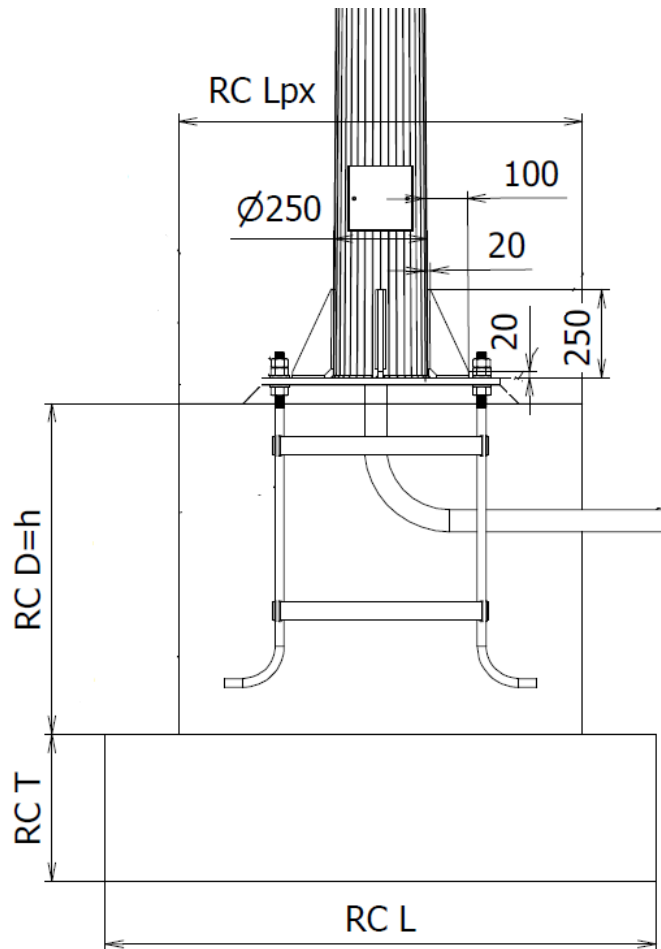

Dimension Chart

L_{px}	850 mm	Concrete
L	1400 mm	
D	800 mm	
T	400 mm	

List of Material Required

1	1.362 Cubic meter of concrete -3000 psi or better.
2	4-M24 Anchor Bolts. One end is bent into a hook shape.
3	4-M24 Nuts.

4	4 galvanized washers.
5	Electrical conduit, 100 mm diameter pipe or similar, maybe needed for underground wiring, if applied.

- 400mm height from the bottom should be expanded to L 1400mm x W 1400mm.
- Insert 4 threaded M24 Anchor Bolts with holding templates and secure them on the position. Make sure there have at least 100mm of thread above the concrete level.
- Fix the conduit through the center of the template and push the other end of the conduit to the side of the foundation (if applied).
- Pouring concrete by using a vibrating poker to remove air voids from the pour. It is very important to make sure the all eight rods are hooked under the rebar. Once the concrete is all poured, make sure that the template has no air voids directly underneath. More importantly, make sure the template is leveled out.
- Next, clear excess concrete from above the template and use a suitable cover to prevent the foundation from rain. Wait until the concrete has set completely before removing the template (It will take one to four weeks) .

Figure 3-4 Anchoring Templates

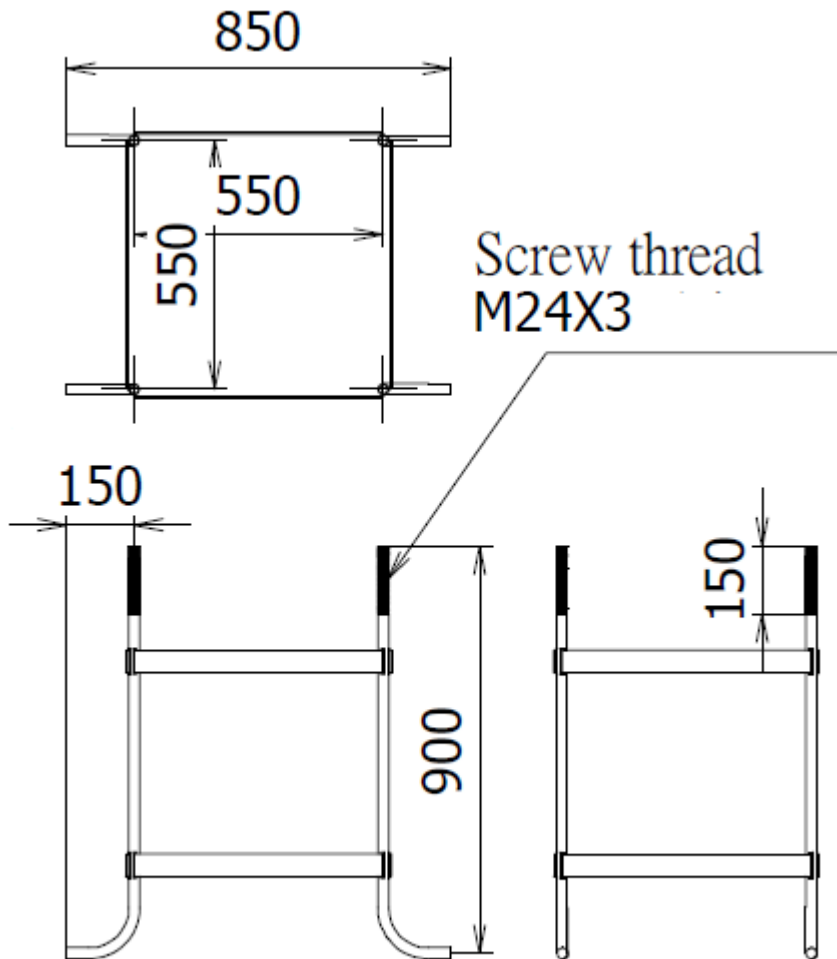

Just remember, a solid with perfect leveled foundation is one of the key factors to achieve the success of the installation.

3.3.2 Roof Foundation

Installation of the DS-700 VAWT System on the roof may be much easier than it is on the ground. But special thought of the building structure has to be carefully taken into account before the installation.

We strongly suggest that the location on top roof surface should be above the concrete beam. Any surface other than concrete, the users should contact their own

architect or structure engineer for advice and take their own responsibility for any possible dangers.

The concrete roof should be thick enough to allow 100mm drilling down from the surface. Please follow the template explained in Section 3.3.1 and use this template as a guide and drill four $\varnothing 25$ holes 100mm deep down to the surface. Insert and secure four threaded rod to each hole, use 4mm plywood to make a square holding template with inner dimension T1 x T2 x T3, pour the concrete into this square template, then put the first template on top of the square template to hold four rods temporarily before the concrete set completely and keep the surface leveled.

Figure 3-5 Foundation for Roof Installation Reference

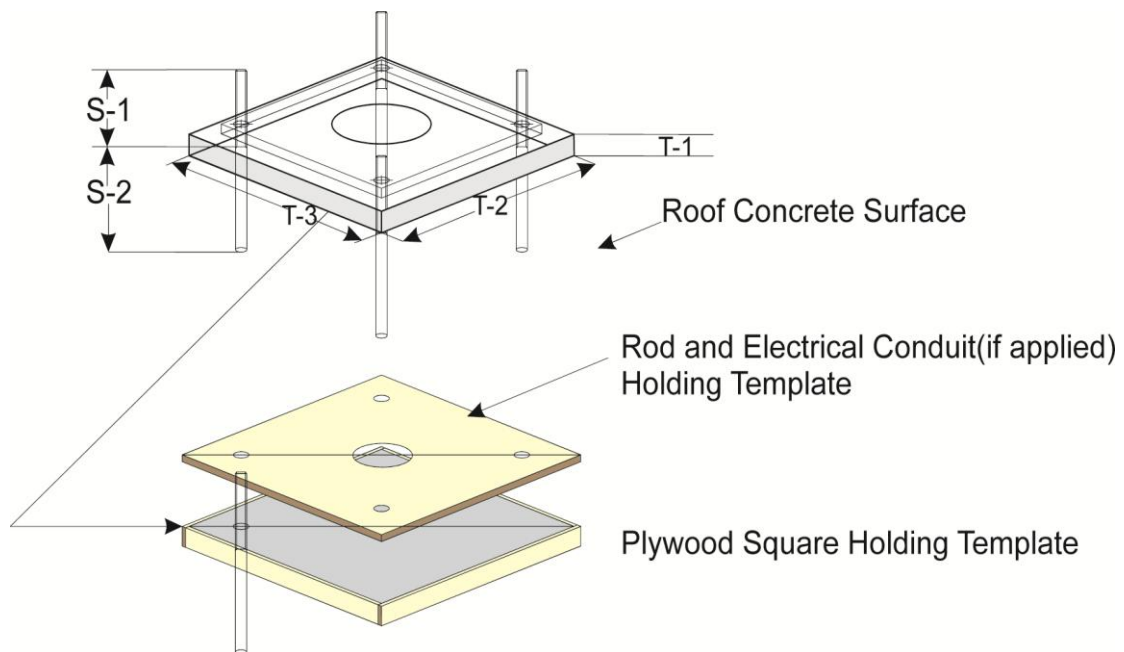

Dimension Chart

T-1	30 mm	
-----	-------	--

T-2	650 mm	
T-3	650 mm	
S-1	60 mm	
S-2	100 mm	



WARNING

- Although, the DS-700 VAWT System is designed to be installed on the roof alternatively, but Hi-VAWT does not recommend to do so unless you are 100 percent sure that the structure of the building is capable of doing so.
- Please consult your local structural engineer and carefully evaluate such implementation before taking any further actions.
- It is user's responsibility to make sure that the structure of the building is able to sustain the force of operating DS-700 Wind Turbine System on the roof. Hi-VAWT is not responsible for any potential damage or dangerous factors caused by insufficiency of structural design of the building.
- Please closely follow your local government's regulations regarding related issues if you are going to install DS-700 on the roof.
- If you are going to install the DS-700 on the ground level, please consult your local civil engineer and carefully evaluate the nature of the soil and design of the foundation accordingly.

4. DS-700 Assembly and Installation

Before starting the assembly and installation of the DS-700 Wind Turbine System, please well prepare all required tools to complete the assembly and installation.

4.1 Tools Required for Assembly and Installation

As the DS-700 is factory pre-assembled, only a few tools required for finishing entire assembly and installation. We are strongly recommend having a crane with suitable capacity to haul up the mounting mast to desired location and also lift up the DS-700 to the mounting flange. Please refer to Figure 4-1 for your tool preparation.

Figure 4-1 Required Tools for Assembly and Installation

DS-700

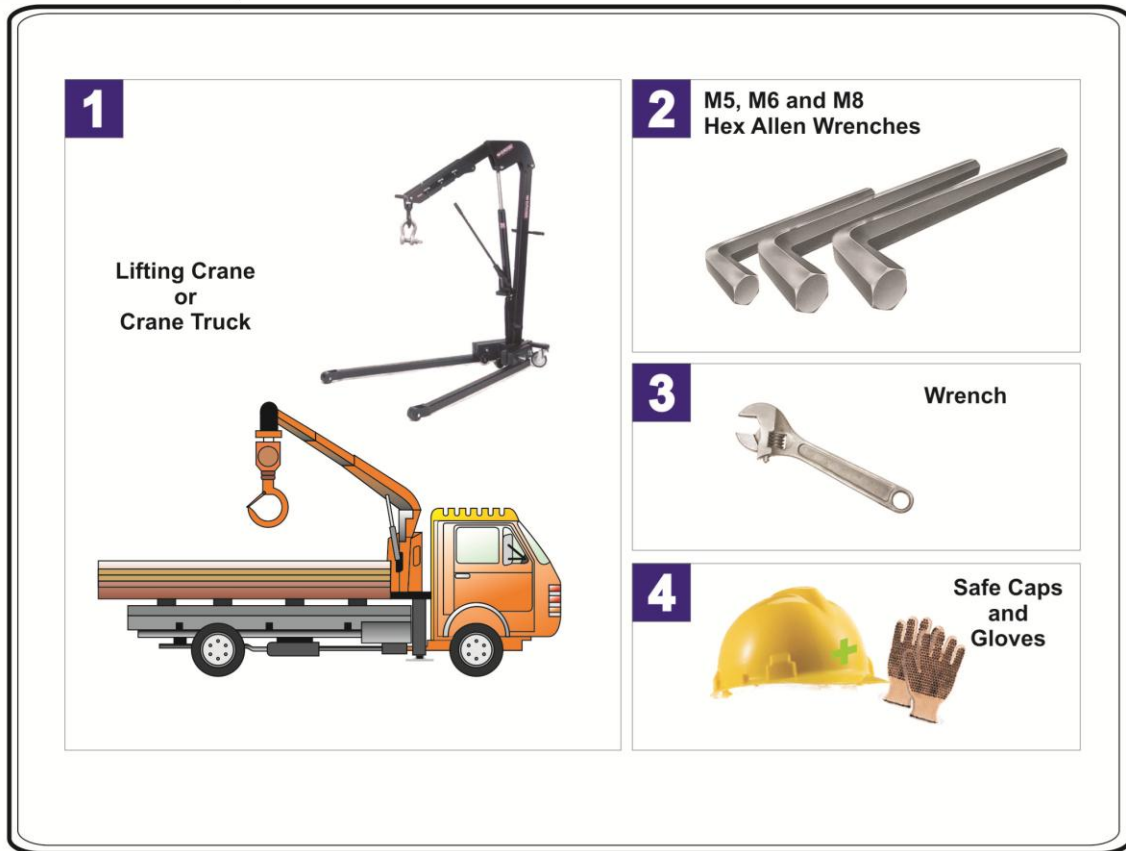
Assembly and Installation Tools

CAUTION

- We strongly recommend you to prepare all suggested tools before proceeding the assembly and installation.
- Please always keep safety in mind while working on the assembly and installation.
- Preparing any extra equipments or safety devices accordingly if instructed by your local authority.

4.2 DS-700 VAWT Assembly

There are only a couple of steps to assemble the DS-700. Please follow the Figure 4-2, 4-3 and 4-4 *DS-700 Assembly Procedures* to complete the assembly.

Figure 4-2 DS-700 Assembly Procedures - 1

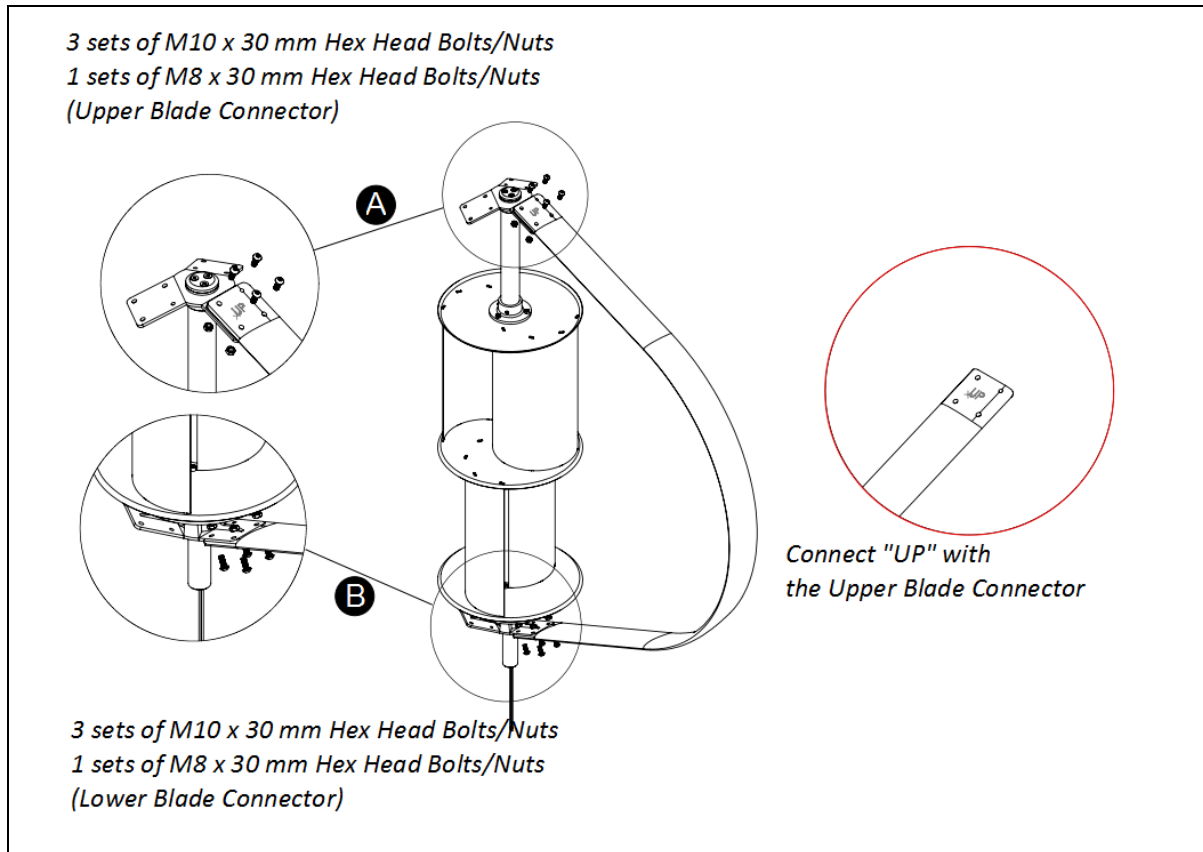

Insert 3 M10 x 30mm Hex Head Bolts/Lock Nuts and 1 M8 x 30mm Hex Head Bolt/Lock Nut for each one of the blades on the upper blade connector. Do not lock these four bolts yet until another 3 sets of M10 x 30mm Hex Head Bolts/Lock Nuts and 1 set of M8 x 30mm Hex Head Bolt/Lock Nut inserted for Lower Blade Connector. Now use Wrench to securely lock blade on upper blade connector and lower blade connector. Repeat this step for the second blade and the third blade and lower section as well.

The alignment of both upper blade connector and lower blade connector has been factory pre-lined up.

 **CAUTION**

- Each blade has a mark of “UP” on one side, please connect the “UP” end with the upper blade connector. Do not connect “UP” end with lower blade connector.
- If you are not able to see the “UP” mark on the blade, you may find three M10 holes and one M8 hole on both blade and connecting plate, just matching up each hole so you won't assemble the blade with wrong direction.

 **WARNING**

- For safety concern, please short circuit the RST Generator Wiring Cables temporarily to stop the rotor from rotation.

Figure 4-3 DS-700 Assembly Procedures – 2

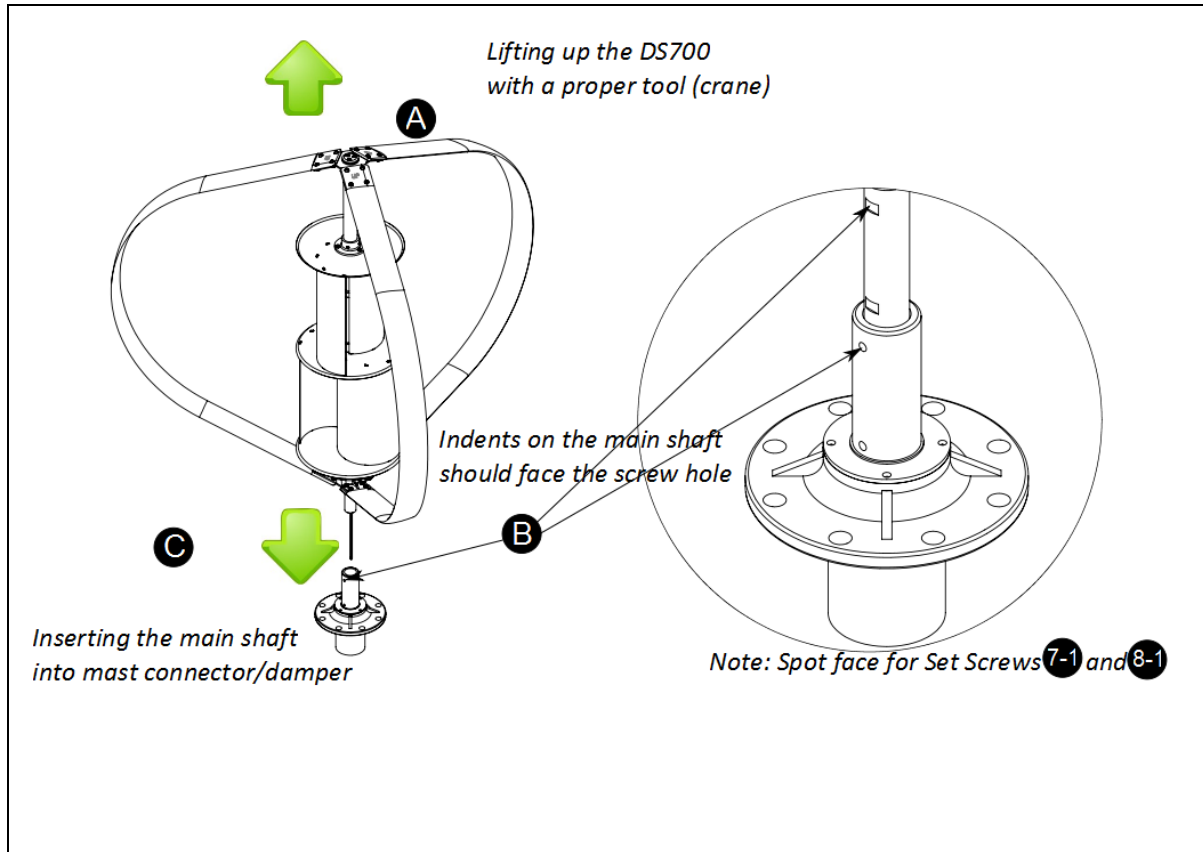

Make sure that all three blades have been securely locked on both upper blade connector and lower blade connector. Next step is to assemble the DS-700 VAWT System with the Mast Connector/Dumper.

Please use proper lifting device, such as crane, to lift the DS-700 up to the height that enough to put the Mast Connector/Damper under the main shaft of the DS-700, then insert the main shaft into the Mast Connector/Damper. There are two indents on the lower main shaft and should be lined up with two lock screw holes on the Mast Connector/Damper.

WARNING

- Indents on the lower main shaft must be lined up with lock screw holes on the Mast Connector/Damper and securely locked. Fail to do so will cause the generator cables broken during break applied.

Figure 4-4 DS-700 Assembly Procedures - 3

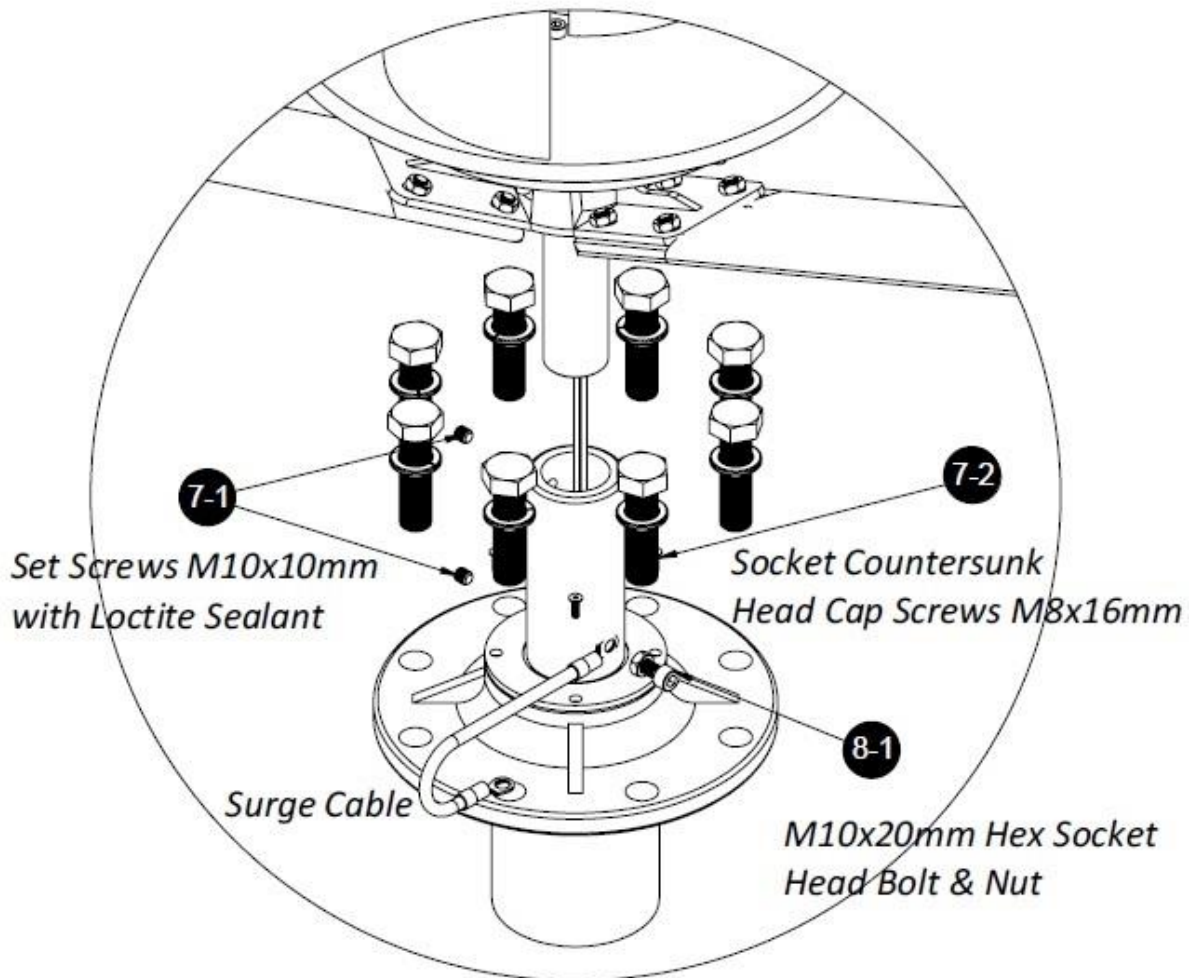

Use the M10 x 10mm Hexagon Socket Screw to lock the upper hole and M10 x 20mm Hexagon Socket Head Bolt and Nut to secure lower section with the surge wire.

4.3 DS-700 Installation

WARNING

- Double check with assembly procedures and make sure all screws are securely locked. Any loosen screw will cause serious vibration and parts damaged.
- If you are going to install the DS-700 VAWT System at certain height, please have proper safety devices ready for proceeding installation.

Figure 4-5 DS-700 Installation Procedures - 1

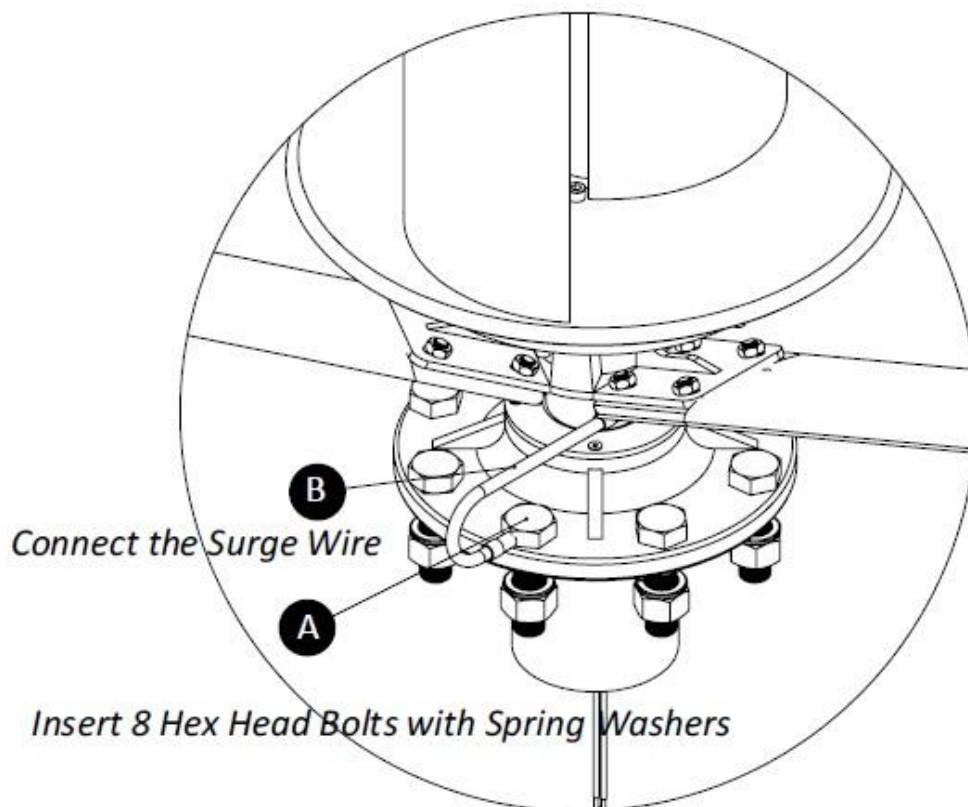

In Figure 4-5, please insert 4 Hex Head Screws with Spring Washers and connect the Surge Wire under one of the washers.

Figure 4-6 DS-700 Installation Procedures – 2

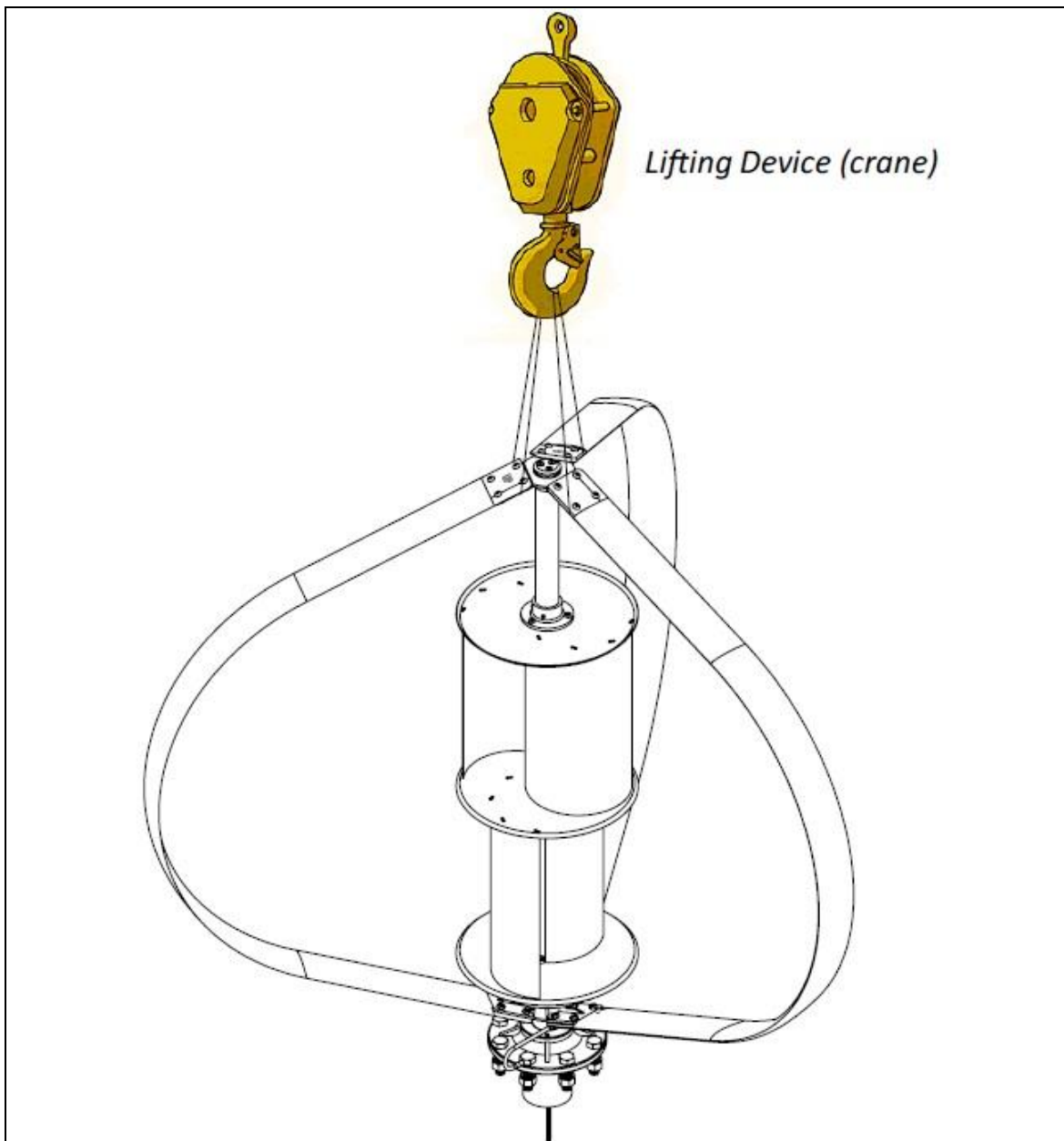

Use proper lifting device (Crane) to lift up the DS-700 above the mast flange.

 **NOTE**

- There are 3 proper size of wires should be pre-installed inside the Mast
- Securely connect the RST Generator Wires with these 3 pre-installed wires.

Figure 4-7 DS-700 Installation Procedures - 3

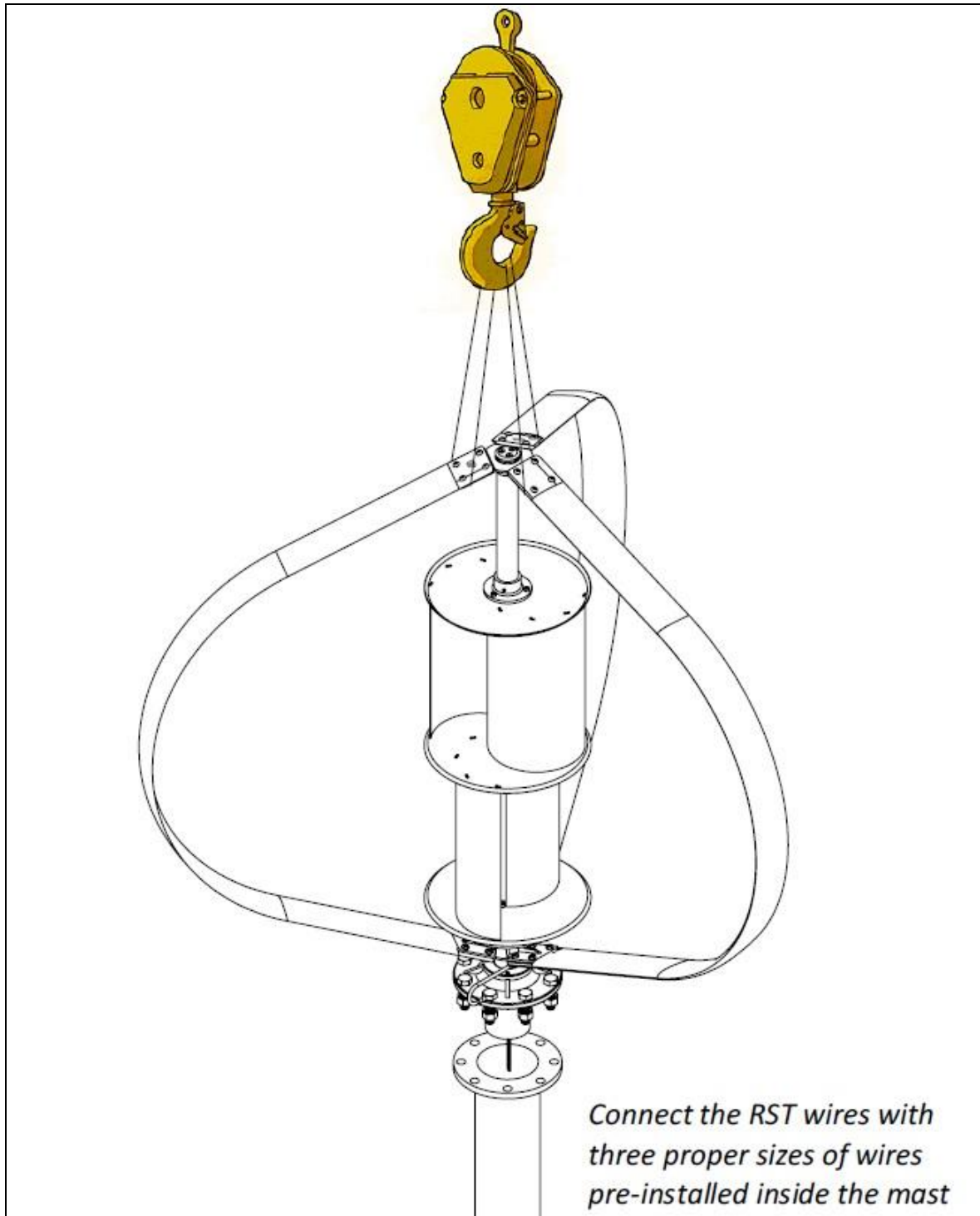

 **NOTE**

- Please refer to the Chapter 5 Wiring section for detail.

Figure 4-8 DS-700 Installation Procedures - 4

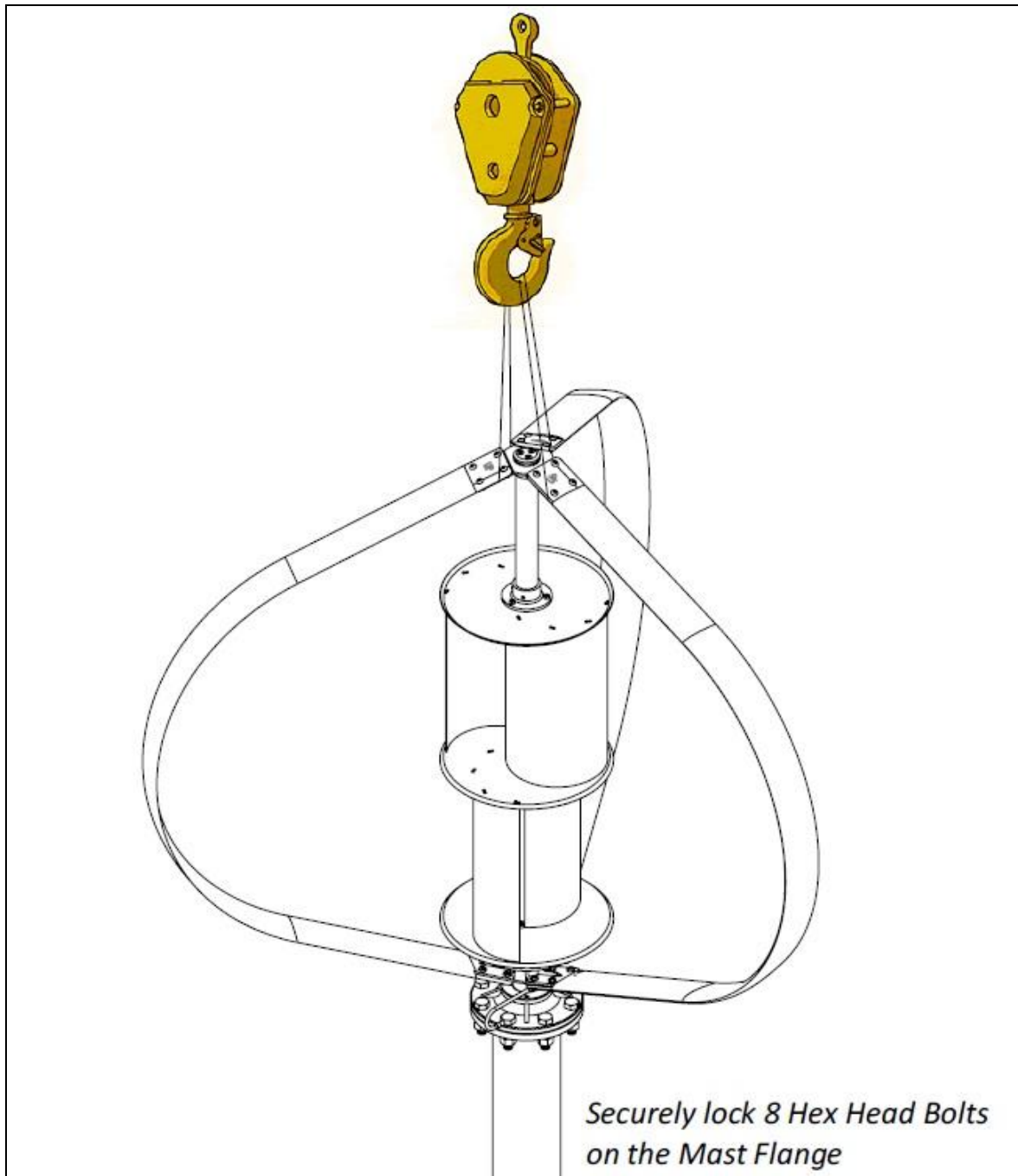

Vertically insert the DS-700 into the Mast, and then securely lock Mast Connector/Damper with the Mast Flange by 4 Hexagon Head Bolts.

After the completion of this step, you have finish the DS-700 Wind Turbine System and ready for further wiring procedures.

5. Wiring

5.1 General Information

Please refer to all local and national codes or special regulations to be followed before installation. All works on the electrical system like installation, maintenance, and repair should be carried out by qualified technicians and make sure that they read all technical information and instructions contained in related manuals.

The wiring diagram should be planned ahead and make sure all required wiring components are well prepared accordingly.

CAUTION

- Carefully plan all required electrical components, and install electrical components first before any electrical connection.
- Make sure that batteries (if applied) should be disconnected all installation works are completed.
- All electrical power cables should be physically protected. Run the wires inside the mast of conduit for maximum protection.

5.2 DS-700 Wire Size

The cross section of the wire to be used depends on its length, resistance and rated current. All electrical systems lose energy from the resistance of the wire used. Larger wire size has smaller losses, but can be considerably more costly.

Closely look at the site that the DS-700 VAWT System is to be installed and measure the following distances:

- Distance between DS-700 VAWT and the location of DS-700 Controller.
- Distance between the solar panel and the DS-700 Controller.
- Distance between the photodiode and the DS-700 Controller.
- Distance between the DS-700 Controller and the Battery. It is recommended that the length between DS-700 Controller and Battery is no longer than 5 meters.

Please follow the reference table below for wire sizing:

Table 5-1 Wire Sizing Reference

Distance Between Generator and Controller					
	0-10m	10-20m	20-30m	30-50m	>50m is not suggested.
AWG Gauge	10	10	10	8	

5.3 DS-700 Wiring Diagram

The DS-700 VAWT System is designed in collaboration with MAX-1000 Wind Charge Controller and MAX-1000 Wind Energy MPPT Charger. The wiring diagram will be illustrated in Figure 5-1.



- Hi VAWT Technology Co., Ltd. makes no warranty that DS-700 Wind Turbine System will work with power management devices other than MAX-1000 in terms of performance and functionality.

Figure 5-1 Wiring Diagram for Wind Energy MPPT Charger (MAX-1000)

MAX-1000 Wiring

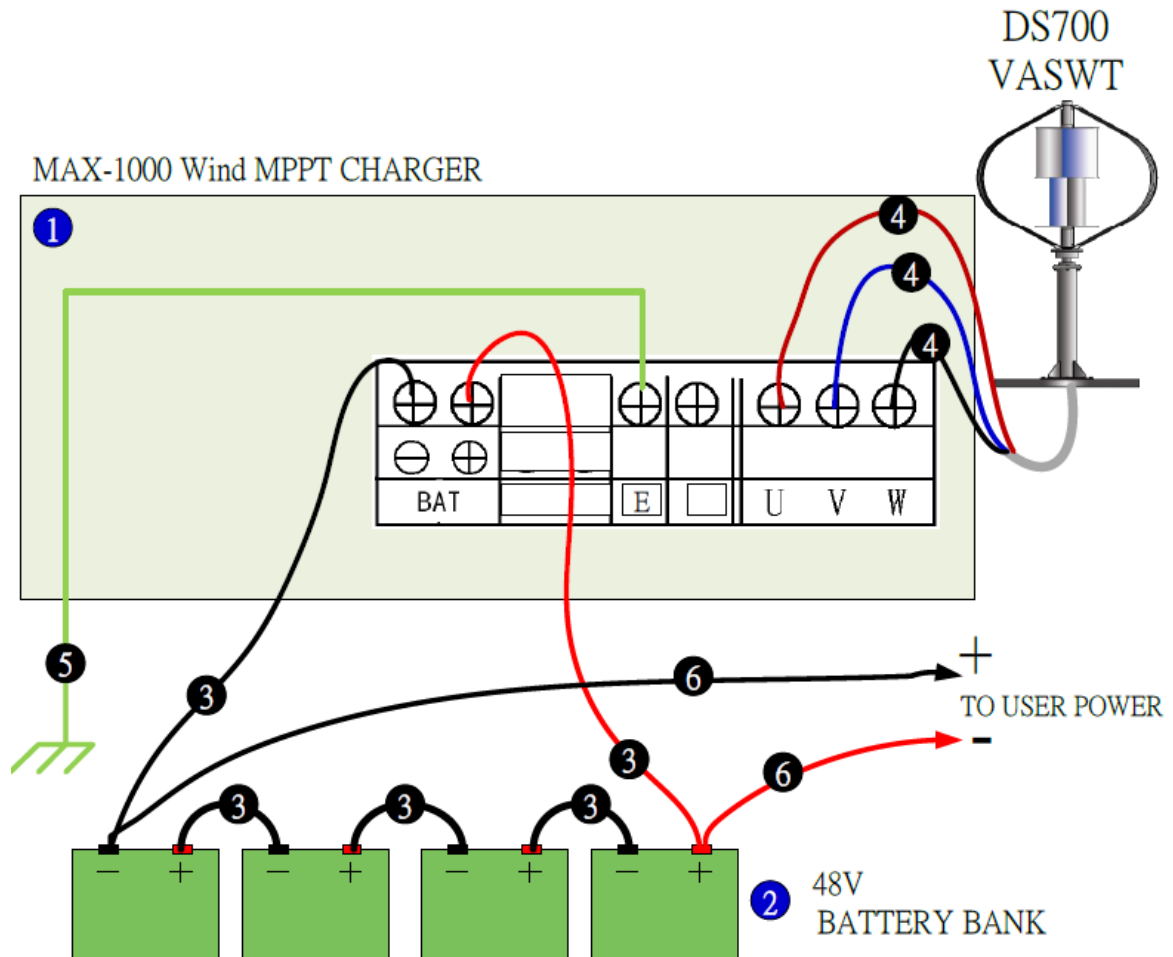

Table 5-2 DS-700 Wiring Size Reference (MAX-1000)

	Description	Wire Size
①	Wind Energy MPPTCharger (MAX-1000)	
②	Deep Cycle Battery Bank 48V 100Ah(minimum)	AWG#10
③	Power Wires between charger and battery bank	AWG#10 (Within 5 Meters)
④	Power Wires between Charger and wind turbine	AWG#10
⑤	Grounding Wire	AWG#10
⑥	Power Wires between charger and user power	AWG#10

**NOTE**

- Please refer to the MAX-1000 Wind Charge Controller / Wind Energy MPPT Charger User's Manual for further information.

5.4 Grounding

In order to protect the DS-700 Wind Turbine System against damage by lightning, static or over voltage, properly grounding the DS-700 Wind Turbine System is very important. Grounding procedures must be followed along with any local electrical codes.

The design of the grounding system depends on the local conditions, like the site of the installation, type of soil, or a grounding bus already existing. If you are in doubt, contact your local electrician for more information.

WARNING

- SEVERE TURBINE DAMAGE CAN RESULT FROM IMPROPER GROUNDING!
- FAILURE TO PROPERLY GROUND WILL VOID THE WARRANTY.

5.5 Fusing

To protect the battery against short circuit, fuse must be installed in the positive line between the Controller and Battery. The recommended fuse type is 30amp DC Slow-Blow fuse for 48V system or appropriate automatic circuit breaker.

The fuse must be placed as close to the battery as possible, however, not in the same compartment. Unsealed lead-acid batteries have vent holes releasing hydrogen which forms detonating gas with the ambient air. A spark when blowing the fuse (or releasing an automatic circuit breaker) can detonate the explosive mixture.

5.6 Stop Switch

A Stop Switch must be used with the DS-700 Wind Turbine System. This Stop Switch is installed between the DS-700 Wind Turbine and the Controller to provide a convenient method for remotely and manually shutting down the DS-700 turbine. This Stop Switch disconnects the Controller then short-circuits the turbine causing the turbine to stop spinning.

A Triple Pole Double Throw (TPDT or 3PDT) should be used for a 3 phase wind turbine generator equipped with the DS-700.

6. Warranty

The Hi VAWT Technology Corporation (Hi-VAWT) provides one (1) year limited warranty (Warranty Period) for products it manufactures and covers defects in materials, workmanship and quality (Defeats) in the DS-700 VAWT System. The warranty is valid from the date of invoice to the original user. The limited warranty is also transferable and applied to subsequent owners only within the Warranty Period.

Hi VAWT will repair or replace the defective products for free under the following conditions:

- The user has notified Hi-VAWT of the Defeat within the Warranty Period.

- Hi-VAWT verifies the existence of a Defeat that is covered within the limited warranty by its inspection, troubleshooting and any possible mean to identify.

Hi-VAWT has the option to use new or reconditioned parts in performing repair or replacement. Hi-VAWT also reserves the right to use parts or improved design in the repair or replacement.

If you purchase the product from our dealer in your area, contact the dealer for repair or replacement or you may contact us directly at the following numbers:

Tel: +886-2-8601-4373

Fax: +886-2-8601-1263

Email Address: sales@hi-vawt.com.tw

Please provide the proof of purchase (dated invoice) for defective products repair or replacement.

The limited warranty does not apply to any product or part thereof damaged by the following conditions:

- Any alteration to the product either internally or externally, or disassembly of the product.
- Not been used in accordance with the User's Manual supplied with the product.
- Installed and used in an unsuitable environment.
- Operation or installation contrary to instructions pertaining to the product.

- Damaged during shipping, mishandled, neglected, improperly installed.
- Repair or service provided by an unauthorized repair facility.
- Lightning strikes without proper grounding.

Hi-VAWT does not warrant or guarantee the workmanship performed by any person or firm installing its products.

HI VAWT MAKES NO WARRANTY AS TO THE ACCURACY, SUFFICIENCY OR SUITABILITY OF ANY TECHNICAL OR OTHER INFORMATION PROVIDED IN MANUAL OR OTHER DOCUMENTATION PROVIDED BY IT IN CONNECTION WITH THE PRODUCT.

ASSUMES NO RESPONSIBILITY OR LIABILITY FOR LOSSES, DAMAGES, COSTS OR EXPENSES, WHETHER SPECIAL, DIRECT, INDIRECT, CONSEQUENTIAL OR INCIDENTAL, WHICH MIGHT ARISE OUT OF THE USE OF SUCH INFORMATION.

THE USE OF ANY SUCH INFORMATION WILL BE ENTIRELY AT THE USER'S RISK.

 **WARNING** Limitations on Use

Please Note, the Hi-VAWT's DS-700 VAWT System is not intended for use as the power source of life support systems or other medical equipment or devices and Hi-VAWT makes no representation or warranty in connection with any use of the product for such purposes.



Hi-VAWT Technology Corporation
www.hi-vawt.com.tw
No. 168, Jhulin 1st Road ,
Linkou District
New Taipei City 24443, Taiwan